



i

microEnable IV AD4-PoCL

Product Profile of microEnable IV AD4-PoCL

Scalable, intelligent frame grabber for highest requirements on image acquisition and preprocessing

- ◆ All formats of Camera Link standard
- ◆ BayerHQe Quality (5x5)
- ◆ Image Enhancement by On-Board Noise Filter
- ◆ Shading Correction (Offset and Gain)
- ◆ DMA900 / up to 900 MB/s PCIe Data bandwidth (PCIe x4)
- ◆ Camera Simulator
- ◆ Broad support of Third-party software interfaces
- ◆ Versatile application and industry usage
- ◆ Flexible and extensible model series
- ◆ PoCL SafePower



Technical Description

microEnable IV frame grabber with 2* Camera Link ports (MDR26) for 2*BASE, 1*MEDIUM or 1*FULL (incl. 10-taps) configuration cameras, 256MB DDRRAM acquisition buffer, PCIe x4 (quad lanes) PC-interface. Support of PoCL (Power over Camera Link) with SafePower. Documentation, SDK, supporting software tools, functional libraries with acquisition applets and drivers in delivery.

Article Details

Product Name	microEnable IV AD4-PoCL
Match Code	mE4-AD4PCL
Article No.	101644
Category	A-Series (image acquisition board)

Device Features

Processor	System Processor
On Board Memory	256 MByte DDR-RAM
Processor Board Interface	n/a
Data Forwarding	n/a
I/O Module Interfaces	Trigger/GPIO-IF (Opto Trigger, TTL Trigger)



Camera Interface

Standard	Camera Link 2.0, up to 85 MHz Pixel Clock
Configurations	CL-base, CL-dual base, CL-medium, CL-full, CL-deca (80bit)
Connectors	2* MDR26
Cable Length	standard conform
Power Output	PoCL SafePower 4W/12V per cable
Camera Support	Area scan camera, line scan camera
Sensor Type	Grayscale sensor, CFA sensor (Bayer), RGB sensor
Sensor Resolution	32k*64k (area scan sensor), 64k (line scan sensor)
Bit Depth	8-16-bit (grayscale), 24-48-bit (color)
Data Bandwidth	850 MB/s
Test Environment	Camera Simulator

Controls and General Purpose I/Os

Trigger Board GPIO Interfaces	TTL Trigger board: 8 TTL in and 8 TTL out, max. input freq: 20 MHz; Opto Trigger boards (options): Up to 8 single-ended opto-coupled in (4,5V-28V) or 4 differential opto-coupled in (4,5-28V, RS422 compliant); 8 opto-coupled out (4,5V-28V), max. input freq: 1 MHz
On-board GPIO Interface	n/a
On-board Front GPIO Interface	n/a
Synchronization and Control	Configurable Trigger System supporting several trigger modes (grabber controlled, external trigger, gated, software trigger) and shaft encoder functionality with backward compensation, Multi-Camera-Synchronization
GPIO Summary	8in/8out (max.), TTL or opto-coupled



Host PC Interface

PC Bus Interface	PCI Express x4 (Gen1), DMA900
PC Bus Interface Performance	up to 900 MB/s (sustainable)

Physical and Environmental Information

Dimensions	PCIe Standard height, half length card: 167.64 mm length x 111.15 mm height
Approximate Weight	126 g
Power Consumption / Power Source	12V, 1000 mA
Operating Temperature	0 - 40°C (32°F - 131°F), (optional -60°)
Storage Temperature	-50 - 80°C (-58°F - 176°F)
Relative Humidity	pending
MTBF	699.000 h
Compliances	CE, RoHS, WEEE, REACH

Software

Software Drivers	Windows 7 / 8 (32-bit), Windows 7 / 8 (64-bit), Linux 32-bit, Linux 64-bit
Software Tools	microDisplay (Acquisition control and viewer), microDiagnostics (Service tool), GenICam Explorer (Camera configuration tool), SDK, Documentation, Device Drivers
Software API	Silicon Software SDK, .net interface
FPGA Programming	not programmable
BV Software Compatibility	Common Vision Blox, Halcon, LabView, VisionPro, MIL, Sapera, Streampix, SAL3D, 3D Express, Heurisco

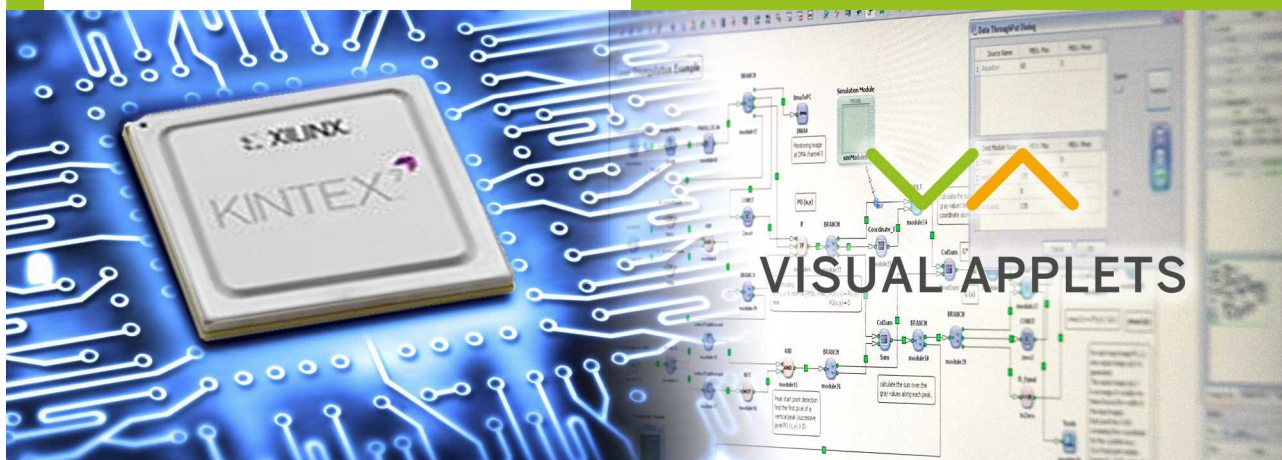

VisualApplets

Often, the goal of industrial image processing applications is to find 100% of all errors and to work in high resolution to identify even the smallest details, to acquire images in the shortest time possible, to detect defects and to forward the results. These tasks frequently require more computing power than a "standard system" can offer. There are solutions that begin the image processing right after the acquisition process but before the camera images are written to storage and taken over by the software.

The processors used in such solutions are designed for image processing. They process data with extremely high parallelism, thus guaranteeing the necessary data throughput. On all its frame grabbers, Silicon Software uses this FPGA technology. In the A-Series (frame grabbers with expanded image recording functions), we have already programmed important and valuable functions that can be activated via the configuration software. For V-Series models (programmable frame grabbers for individual image processing functions), we have released the FPGA for you, as our customer, for individual programming.

To ease your entry into hardware programming, we have developed software that enables you to graphically program FPGAs using data flow diagrams. This program is called VisualApplets.

VisualApplets makes it possible for you to write complex applications on your own, even after a short time, for the special processor. Even without hardware programming expertise. The program is geared toward both software programmers and application engineers. Program in the language of image processors without using hardware code. The simulation works with a rapid image output with which you can immediately check your algorithms and image processing steps.

We have built in many automatic correction functions and generators so that you can concentrate on your actual work. And should an error sneak in, you are immediately made aware of it in color, and solution approaches are offered to you.

An SDK output generates executable example code in C/C++, listing all the parameters (hardware register), in order to control the image processing application out of your software.

What does real time mean? By using FPGA technology, you have a deterministic relationship to the application that works after the start with a constant delay (latency) that is determined by the image processing algorithm. In most cases, this latency lies in the micrometer range.

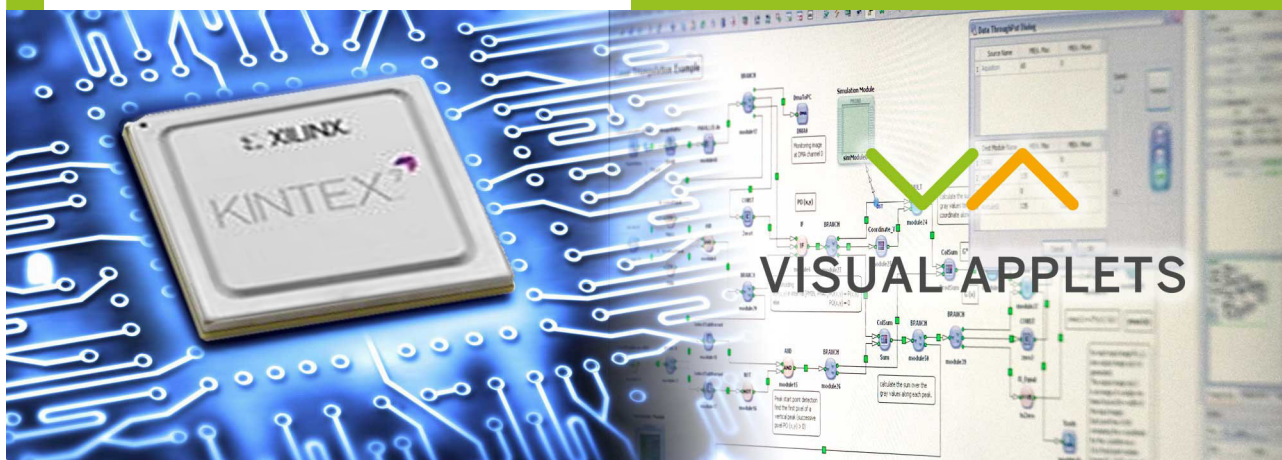

VisualApplets (ctd.)

VisualApplets simplifies image processing programming for you. You can fall back on libraries with over 200 operators. You can create your own libraries for commonly used image processing steps or import them from available hardware code (EDIF over VHDL/Verilog).

With VisualApplets, you acquire a powerful tool that offers you new ways forward for your system solution.

VisualApplets is available for Silicon Software V-Series frame grabbers, including VisualApplets-compatible cameras and imaging devices.

V-Series frame grabbers are already pre-licensed for use with VisualApplets in the basic version. VisualApplets offers several versions of its programming environment; additionally, you can license further operator libraries to expand the range of functions.

In 2006, VisualApplets was honored with the international Vision Award. It has been successfully used in the most diverse industrial applications, both using frame grabbers and in VisualApplets-compatible industrial cameras and image processing devices.

Technical Setup

Board/Housing Measurement

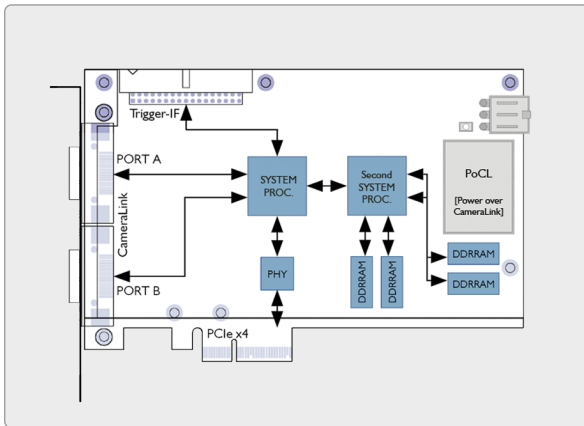
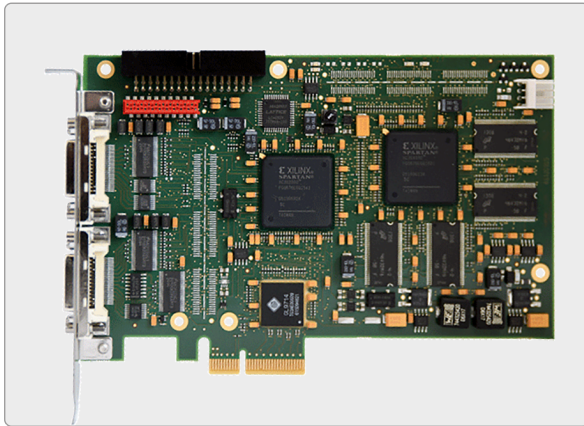

PRODUCT VARIATIONS

microEnable IV AD4-CL microEnable IV AD4-CL (LVTTTL) microEnable IV AD4-PoCL (LVTTTL) microEnable IV VD4-CL microEnable IV VD4-CL (LVTTTL) microEnable IV VD4-PoCL microEnable IV VD4-PoCL (LVTTTL)

PRODUCT EXTENSIONS

Opto-coupled Trigger Board - mE5Match Code: TRG-OPTO5, Art.No.: 155010 Opto-coupled Trigger Board - mE4 (Pull up)Match Code: TRG-OPTO4-PU, Art.No.: 101266 Opto-coupled Trigger Board - mE4 (Pull down)Match Code: RG-OPTO4-PD, Art No.: 101433 Opto-coupled Trigger Board - mE4 (DS Pull up)Match Code: TRG-OPTO4-DSPU, Art No.: 101435 Opto-coupled Trigger Board - mE4 (DS Pull down)Match Code: TRG-OPTO4-DSPD, Art No.: 101437 Opto-coupled Trigger Board - mE4 (DS/SE Pull up)Match Code: TRG-OPTO4-DSSEPU, Art No.: 101443 Opto-coupled Trigger Board - mE4 (DS/SE Pull down)Match Code: TRG-OPTO4-DSSEPD, Art No.: 101444 TTL Trigger Board - mE4Match Code: TRG-TTL4, Art No.: 101248 microEnable 4 Temperature UpgradeMatch Code: TU4, Art.No.: 101570

ORDERING INFO

- ◆ microEnable IV AD4-PoCL, mE4-AD4PCL, Art No.: 101644



Copyright © Silicon Software, 2018

Generated on 02. November 2018



Silicon Software GmbH
Konrad-Zuse-Ring 28
68163 Mannheim
Germany

[t] +49.621.798507-0
[f] +49.621.798507-10
[e] info@silicon.software
[w] <https://silicon.software>



Silicon Software Inc
1 Tara Boulevard, Suite 200
Nashua, NH 03062
USA

[t] +1.603.32471-72
[f] +1.603.96609-56
[e] americas@silicon.software
[w] <https://silicon.software>



Silicon Software Americas Inc
3055 St-Martin Blvd., Suite 500
Laval, Qc., H7T0J3
Canada

[t] +1.888.808 3670 Ext 101
[f] +1.888.808 3670
[e] americas@silicon.software
[w] <https://silicon.software>

We reserve the right of technical modifications, changes of the equipment features and adaptations to current specification. Typing and setting mistakes and other errors cannot be excluded and are therefore also reserved. In recent publications availability, also by technical generation, previous cease to be valid.