

rc_randomdot

Quick Start Guide



English

Table of Contents

1. Introduction
2. Prerequisites
3. Additional Information
4. Mounting the Projector
5. Connecting the Cables
6. Projector Pin Assignments
7. Projector Specifications
8. Operating the Projector
9. Adjusting Focus and Aperture Settings
10. Support
11. Conformity

Warnings

This guide shows how to initially connect and configure the rc_randomdot projector. It is not meant to provide instructions for permanent installation or operation in an industrial environment.

Before operating the rc_randomdot, please read the full rc_randomdot and rc_visard documentation.

Please refer to the full manual for connection requirements and cable specifications.

Do not look directly into the projected beam. Do not look at the beam with an optical instrument.

Looking at the sun through the lens might cause damage to the eyes. Directing the lens at the sun might start a fire.

The rc_randomdot is protected according to IP54. High humidity or temperature can damage the device. Do not operate in an environment where combustible or explosive fumes may occur.

All cables must be secured.

Make sure to use the correct power supply, which conforms to the EN 62368-1 standard, and check polarity and connections.

1. Introduction

Basler offers the rc_randomdot projector as a specifically tailored projector that can be used as an enhancement to the rc_visard when the perception of particularly difficult scenes with little or no natural texture is required. It can be mounted over a scene or directly on any rc_visard. It increases the scene density and hence improves the quality of stereo matching when the natural scene texture is low. This guide will help you get the projector connected and set up. This guide applies to both the white and the IR version of the rc_randomdot.

2. Prerequisites

This guide assumes that you have purchased the following components:

- rc_visard 160 or rc_visard 65
- rc_randomdot projector with 30 cm connection cable
- 24V power supply, M12 power adapter cable, and M12 to RJ45 network cable
- rc_reason IOControl license

This guide also assumes that you have read and understood the rc_randomdot documentation, the rc_visard quickstart guide and complete documentation, and that the rc_visard is successfully connected and configured.

3. Mounting the Projector

The rc_randomdot projector should be mounted as close as possible to the rc_visard in order to reduce occlusions. If possible, we recommend to attach the projector directly onto the rc_visard using the mounting bracket and included M4x10 Tuflok® coated screws. A medium-strength thread-locker or Tuflok® screws must be used to protect against vibrations. Screws must be tightened to 2.4 Nm.

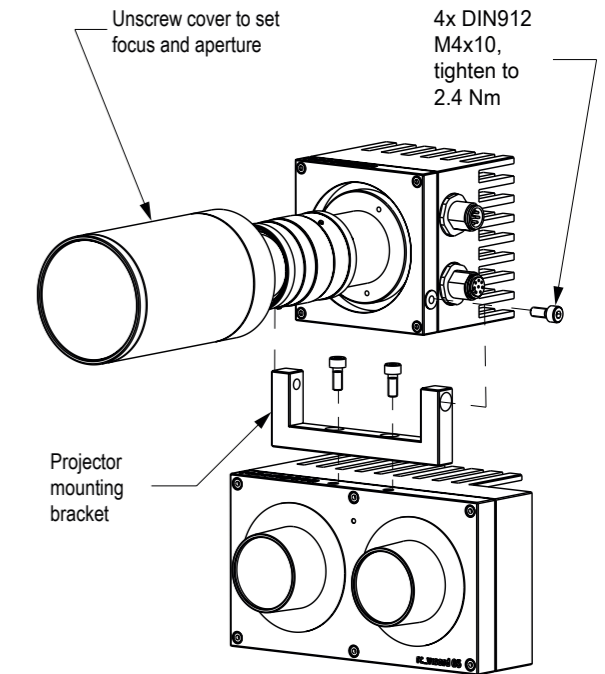

4. Connecting the Cables

Please note that a 24V power supply with sufficient wattage is required to power both the rc_visard and the rc_randomdot together. The power supply must be connected to the top (plug) M12 connector of the rc_randomdot. The bottom (socket) M12 connector is connected to the bottom M12 connector of the rc_visard with the supplied 30 cm M12 shielded cable. Make sure to check the polarity of your power supply as reverse polarity will damage the rc_randomdot.

Now you are ready to power up the rc_visard and the rc_randomdot.

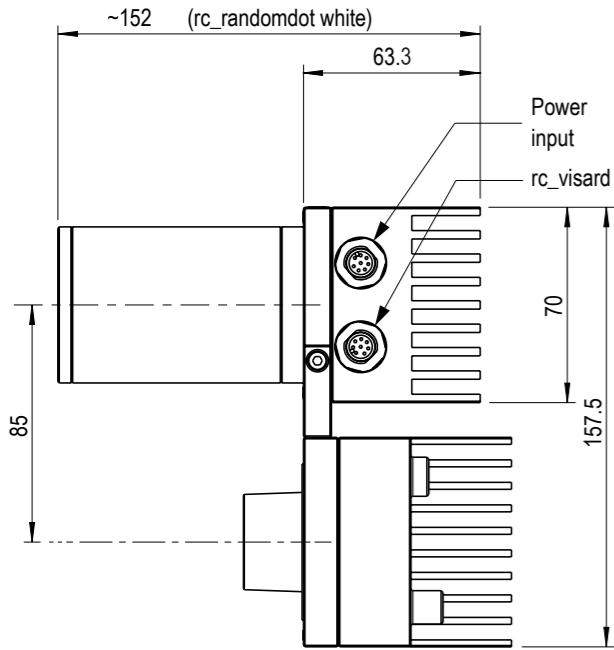

6. Projector Specifications

	White
Illumination Mode	Strobe
Wavelength	5500 K
Power Supply	24 V
Connectors	M12, 8 Pin, A-coded
Weight	660 g
Dimensions	70 mm x 152 mm
Temperature Range	0° C - 45° C (passive cooling)
Protection Class	IP 54
Lens (C-Mount)	12 mm, f min 1:1.4
Projection Angle	62° x 48°

7. Operating the Projector

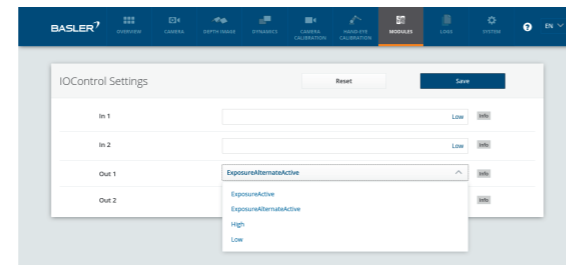

The rc_randomdot projector is controlled via the GPIO Out1 of the rc_visard. A valid IOControl license is required.* State and behaviour of the rc_visard's GPIOs can then be controlled via the rc_visard's WebGUI IOControl panel from the Modules tab. Starting with rc_visard firmware 20.10, Out1 is set to *Low* by default, turning the projector off.

ExposureActive turns on the rc_randomdot for exactly the exposure time of every image.

High will turn the projector on continuously, but reduce power to 18% to protect the light source.

Typically, the user will select *ExposureAlternateActive* mode, in which the rc_randomdot is on only for the exposure time of every second image. Images with projected pattern are used for computing depth images. Images without pattern can be used for texture or other image processing modules.

Note: In *ExposureAlternateActive* mode, the rc_visard's auto exposure algorithm ensures that images with pattern are correctly exposed in order to produce dense disparity images. As identical exposure settings are used for the images without pattern, which are displayed in the WebGUI, those might be underexposed depending on overall illumination conditions. This effect can be minimized by properly adjusting environmental light conditions, projector aperture, and exposure time.

8. Adjusting Focus and Aperture Settings

Remove the protective lens cap by unscrewing it. To change focus and aperture settings, loosen the three small Phillips screws on the respective lens ring, turn the ring to the desired setting and lightly tighten the screws again. For focus adjustments, the projector should be turned on permanently by setting the Out1 mode to *High* in the WebGUI. For aperture adjustments, Out1 should be set to *ExposureAlternateActive* and exposure mode should be set to *'Auto'* in the WebGUI Camera tab.

Starting from the largest aperture (smallest f-stop number on projector lens), reduce light output by decreasing the aperture until the white (high confidence) areas in the confidence image start to get smaller or darker. At the same time, the camera image should become less underexposed. At this point, slightly open the aperture again to find a suitable compromise.

Replace the protective lens cap to restore the IP54 rating of the projector.

9. Support

Please refer to Web GUI and documentation. For further support issues, please refer to <https://www.baslerweb.com/en/sales-support/support-contact/> or contact the Technical Support Team: Europe, Middle East, Africa: +49 4102 463 515 | support.europe@baslerweb.com The Americas: +1 610 280 0171 | support.usa@baslerweb.com Asia-Pacific: +65 6367 1355 | support.asia@baslerweb.com

10. Conformity

rc_randomdot Projector



For detailed information on the projector, please refer to the documentation at [baslerweb.com/stereo-cam](https://www.baslerweb.com/stereo-cam)

5. Projector Pin Assignments

Pin number	Cable Color	Designation	Details
1	White	nc.	
2	Brown	+24V	2.75 A @ 24 V
3	Green	GPIO in 2	passed to rc_visard
4	Yellow	GPIO GND	
5	Grey	GPIO Vcc	
6	Pink	GPIO out 1	rc_visard exposure signal
7	Blue	GND	
8	Red	GPIO out 2	from rc_visard

For rc_visard pin assignments and rc_randomdot GPIO operation, please consult the respective documentations of rc_visard and rc_randomdot.

Power Supply

For detailed information on the power supply, please refer to the datasheet at [baslerweb.com/stereo-cam](https://www.baslerweb.com/stereo-cam) Please note: This power supply is not suitable for a permanent industrial installation. It should only be used for setup and testing.

Lens

No electronic components.

Basler AG

An der Strusbek 60-62
22926 Ahrensburg
Germany

Web: www.baslerweb.com
Email: info@baslerweb.com
Phone: +49 4102 463 0